

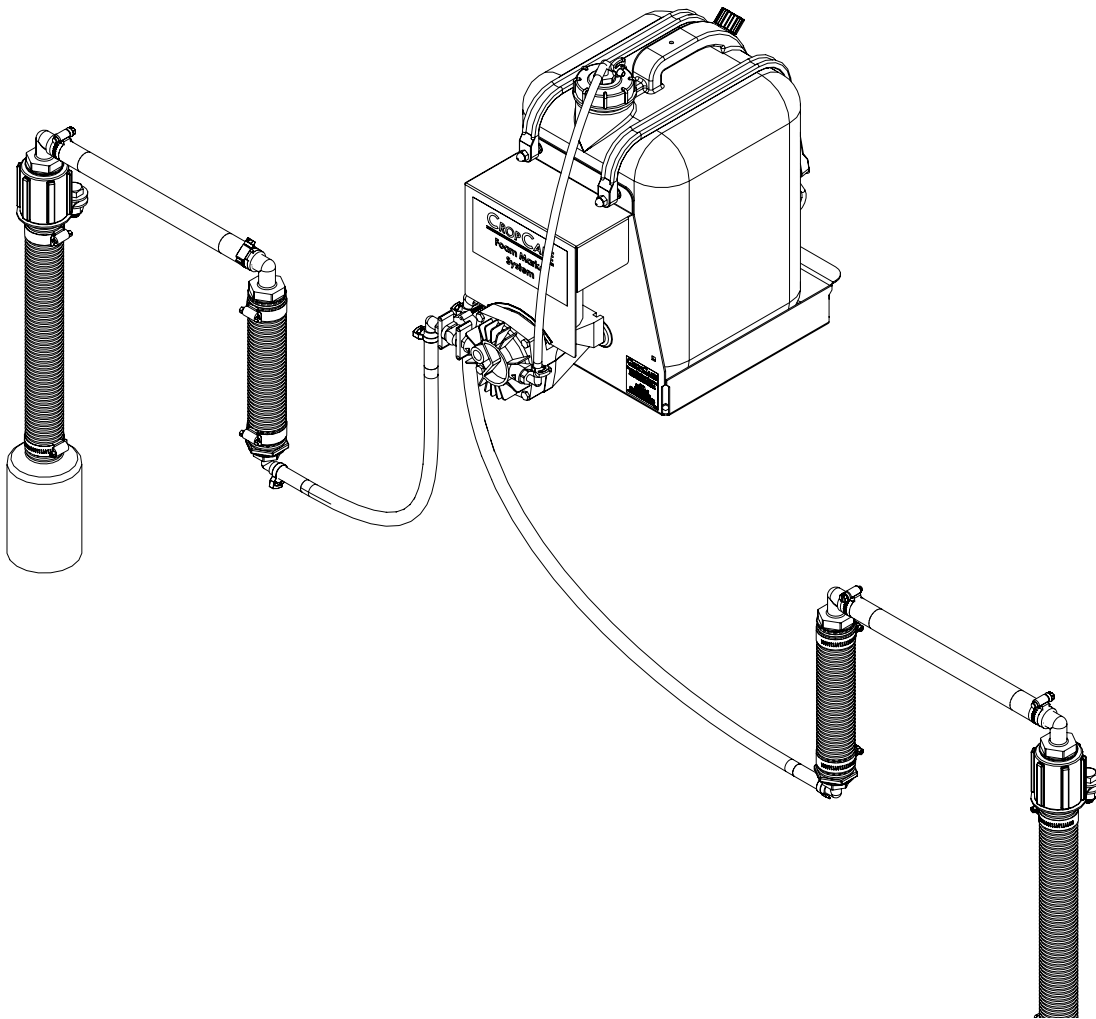

Owner's Manual

5 Gallon Foam Marker Model: F1500A



Manufactured by PBZ LLC
A Paul B Zimmerman Inc. Company
www.CropCareEquipment.com

Form F1500AOM
Rev: C Date: 3/22

Table Of Contents

Specifications.....	2	Troubleshooting	8
Before You Begin.....	3	Wiring Schematic	9
Safety Precautions.....	3	Breakdowns & Parts Lists	10
General Guidelines.....	3	Foam Marker Breakdown.....	10-11
Mounting the Foam Marker	4	Foam Marker Parts List	12-13
Foam Marker Unit.....	4	Compressor Breakdown.....	14
Foam Marker Parts Bag.....	4	Compressor Breakdown.....	15
Wiring Harness	4	Discharge Tube Breakdown	16
Mixing Chambers	5	Mixing Chamber Breakdown	17
Discharge Tubes.....	5	Limited Warranty	18
Discharge Hoses.....	6		
Operating Instructions	6		
Maintenance Instructions	7		
Routine Maintenance.....	7		
Winterizing your Foam Marker	7		

Specifications

5 gallon Foam Marker
Model #: F1500A

Tank Capacity.....	5 gallons
Power usage.....	7 amp draw / 15 amp start load
Min power supply	12 volt / 15 amp
Max continuous run time	2 hours
Max boom length.....	.60'
Wiring Harness24' length
Shipping weight41 lbs

Before You Begin



Please read and understand this manual and its instructions and warnings completely before operating the foam marker.

- Be aware of all safety guidelines, warnings, and cautions including those of the sprayer, no-till drill, or any other piece of equipment that the foam marker may be mounted on.
- Read and understand the warnings and instructions of the foam concentrate that you are using.
- Always use an approved foam concentrate.
- Ensure that you have a power source that meets the requirements of 12 volt DC and 15 amps.

Safety Precautions



General Guidelines

Every year many unnecessary accidents occur due to improper equipment handling and a disregard for safety precautions. You, the operator, can avoid accidents by observing the precautions listed in this section.

- The operator should be a responsible adult. Do not allow persons to operate the foam marker until they have displayed a thorough understanding of foam marker safety precautions and operational use.
- Never attempt to operate the foam marker while under the influence of alcohol or drugs.
- Always use an approved foam solution. Do not, on any occasion, use dish soap, hand soap, or any other cleaning product. The use of an unapproved foaming solution could result in lowered performance or machine damage.
- Do not eliminate the fuse on the battery wiring harness under any circumstances. Elimination of the fuse could result in damage to the machine or personal injury.
- Always disconnect the power before performing maintenance or repairs on the foam marker. Failure to adhere to this warning could result in personal injury.
- When performing maintenance on the foam marker, pay close attention to any moving parts. Be especially aware of the metal fan blade on the compressor.
- Do not touch the surface of the compressor since it may cause burns during and after operation. See the warning label on the compressor.

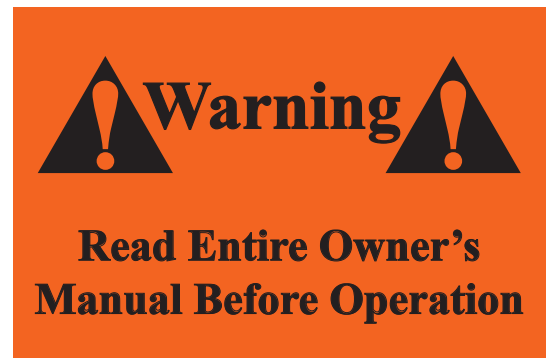

Figure 1: Owner's Manual Decal (DE39)

- Be aware of the location of the owner's manual warning decal on the foam marker's frame. Always replace any warning decals that are not legible or are missing (Figure 1).
- Do not attempt to adjust the foam discharge rate. This rate is preset and should never need to be adjusted. Any such adjustment will void the manufacturer's warranty.
- If there is any portion of this manual that you do not fully understand, please contact the original retailer for more information.

Mounting the Foam Marker

It is important to follow these mounting instructions to ensure that your CropCare® foam marker system operates at its fullest potential. Please note that these are only general instructions for proper mounting and may not be relevant to all applications. In certain applications, you may need be creative in order to achieve the best mounting technique. If you are having trouble mounting your foam marker, please contact the original retailer for service.

Foam Marker Unit

1. Begin by choosing a convenient location that is easily accessible for mounting and filling the solution tank. The foam marker should be mounted where it will receive a minimal amount of dust or dirt. The mounting location must be able to support the weight of the foam marker unit with a full solution tank.
2. Secure the foam marker unit by attaching the foam marker frame to your equipment with bolts. Four square holes are located on the bottom of the foam marker frame. It is recommended to use 3/8" bolts to provide optimal stability.

Foam Marker Parts Bag

Ref #	Qty.	Part Number	Description
1	25	1475UV	Cable ties, 14", black
2	4	6810	Stainless hose clamp
3	4	6828	Stainless hose clamp
4	4	6864	Stainless hose clamp
5	4	HC067	Snap grip clamp, size F
6	4	FW12S	Washer, Flat, 1/2" SS
7	2	H12*114S	Bolt, Hex 1/2-13 x 1 1/4 SS
8	2	NNC12S	Nut, Lock Nylon 1/2-13 SS

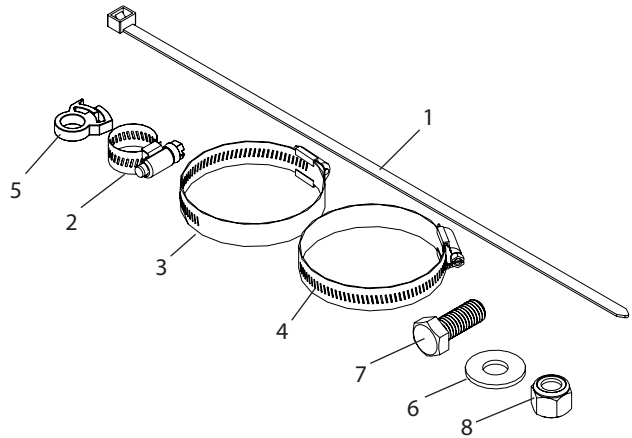

Wiring Harness

1. The compressor wiring harness (F1509A) has a 3-pronged plug (a) on one end and is connected to the compressor and solenoid valve on the other end. Route this wiring harness under the foam marker cover. The compressor wiring harness needs to be connected to the power wiring harness (F1507) which is connected to the power source and the control box (b) (Figure 2).
2. The power wiring harness (F1507) needs to be connected to a 12 volt, 15 amp DC power source. Connect the red wire to a positive power source either at the tractor's battery terminal or at a power access point with at least 15 amp capability. The brown wire needs to be connected to a good ground source or to the negative terminal of the battery (Figure 2).
3. Refer to the wiring schematic (page 9) for a visual representation of the wiring assembly.
4. Ensure that the power source is adequate. If you are using a power access point, ensure that it has at least 15 amp capability.

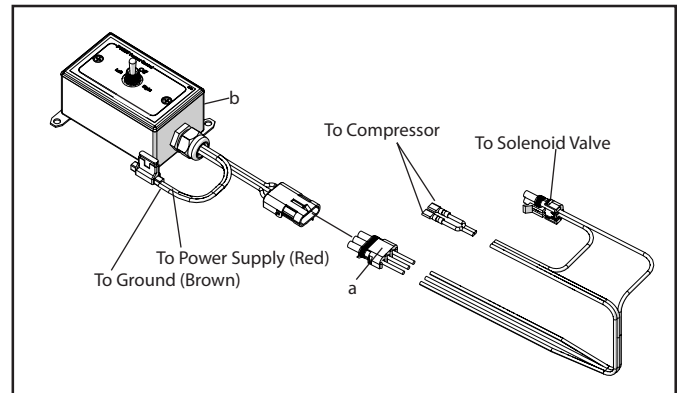

Figure 2: Wiring harness

5. Mount the control box in a location where it is easily accessible for operation. There are two metal tabs with pre-drilled holes on the back of the control box that can be turned out for mounting. It is recommended to mount the control box using bolts through these metal tabs.

NOTE: Make sure the power source that is utilized is rated at a minimum 12 volts/15 amps. Using a 6 or 24 volt power source will cause damage to the machine and will void the manufacturer's warranty.

Mounting the Foam Marker

Mixing Chambers

1. The foam mixing chambers (a) must be mounted in a vertical position and can be secured with the four (two for each mixing chamber) large hose clamps (b) included in the kit. The mixing chambers must be mounted with the 1/2" inlet (from solenoid valve) on the bottom, and the 3/4" outlet (to discharge tube) on the top. They should be positioned behind the sprayer or somewhere on the inner boom wing (Figure 3).
2. It is best to locate the mixing chambers where most of the 3/4" discharge hose can be used. (Limited to 25') This keeps the 1/2" hose shorter and will result in better foaming performance (Figure 3).

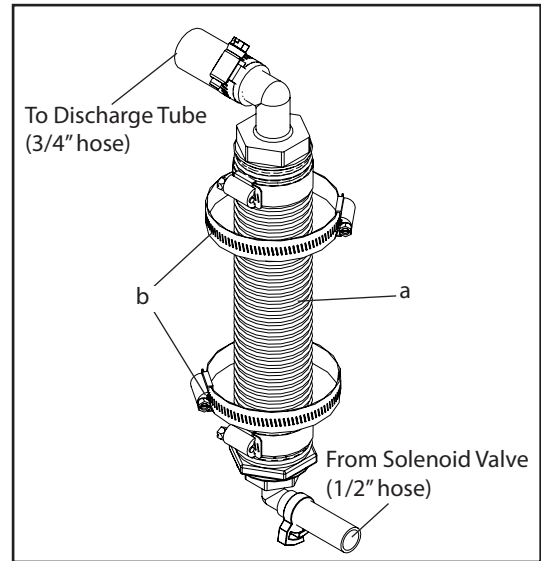

Figure 3: Mixing Chamber Mounting

Discharge Tubes

1. The discharge tubes (a) dispense the foam and should be mounted in the desired foaming position. Generally, they are mounted at the end of a sprayer boom or at the ends of a no-till drill (Figure 4).
2. The discharge tube should be mounted using the 1/2" bolt (c) through the mounting bracket (d) (Figure 4).
3. If you are mounting the tube on a sprayer, a standard nozzle body clamp (e) can be used. Simply mount the clamp on the sprayer's boom and insert the 1/2" bolt through the hole where a nozzle body would normally be inserted and place a flat washer on either side of the clamp as shown (Figure 4).
4. On other applications it is also feasible to simply drill a hole through the equipment frame and thread the 1/2" bolt through the hole and into the top of the discharge tube.
5. Ensure that the discharge tubes do not interfere with the operation of the equipment it is mounted on. For example, make sure that the discharge tubes do not interfere with the spray pattern if you are mounting the foam marker on a sprayer.
6. Discharge tubes can also be fastened with two hose clamps (h).

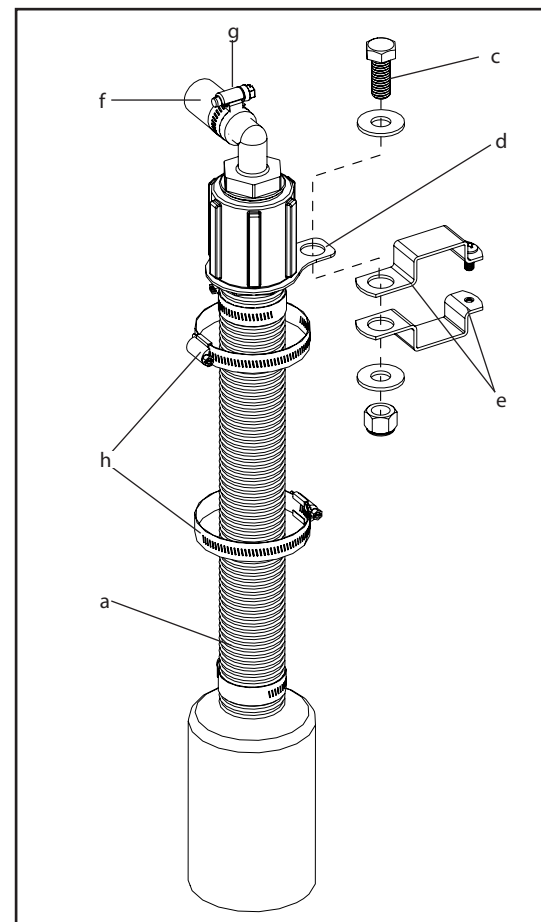

Figure 4: Discharge Tube

Mounting the Foam Marker

Discharge Hoses

1. One 30' length of 1/2" discharge hose is included and may be cut as needed. Begin by attaching the 1/2" discharge hose to the hose barbs (a) on the solenoid valve (b) on the foam marker. It is important that you know which hose barb is for the left and for the right side. Clamp the hose onto the hose barbs with the included nylon hose clamps (c) (Figure 5).
2. Route the 1/2" discharge hoses to the mixing chambers. If you are attaching the discharge hose to a sprayer boom, pay close attention to the positioning of the discharge hose. The hose should be positioned in a manner such that it will not be kinked or pinched when the boom is in the folded or unfolded position.
3. Remember to also account for boom height adjustment or other movements that the hose will be subject to. With the discharge hoses in the correct position, fasten them with the included cable ties.
4. One 50' length of 3/4" discharge hose is included and may be cut as needed. Attach the 3/4" hose (f) to the mixing chambers and route to the discharge tubes. Clamp all ends with the included stainless hose clamps (g) and secure the hose with the included cable ties (Figure 4).

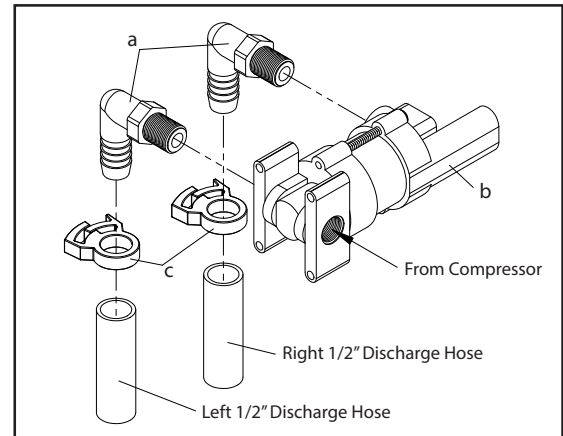

Figure 5: Discharge Hose Mounting

5. Be sure the hoses do not interfere with the operation of the machine.

NOTE: Be sure that the discharge hoses (1/2" and 3/4") are cut at equal lengths on both sides of the foam marker. This will ensure even foam output from both discharge tubes.

Operating Instructions

Before operating the foam marker, it is important that you read this entire manual and know all of the safety precautions. Before operation it is also recommended that you do a thorough inspection of the foam marker. Ensure that all hoses are attached and undamaged and that the wiring harnesses are properly connected to each other and to an adequate power source.

1. Fill the foam solution tank with the proper mixture of water and an approved foam concentrate, according to the foam concentrate's manufacturer.
2. Do not use dish soap, hand soap, or any other unapproved foaming solution as this will cause damage to the machine and will void the manufacturer's warranty.
3. Flip the control switch on the control box to the left or the right to turn on the foam marker. Please note that only one discharge tube can dispense foam at a time.
4. Allow approximately one minute for the foam to reach the discharge tube. Do not attempt to adjust the foam discharge rate. This rate is preset and should never need to be adjusted. Please note: The 5 gallon capacity tank has an average foaming time of two hours. The 12 gallon capacity tank has an average foaming time of four hours.
5. To turn off the foam marker, flip the control switch to the center-off position.

NOTE: If you are operating the foam marker in temperatures below 32 degrees, it is recommended that you add 20% RV non-toxic antifreeze to the foaming solution. This will guard against freezing and breakdowns.

Maintenance Instructions

It is very important to perform maintenance on your foam marker before and after each use and at the end of each season of use. Proper maintenance practices will help to guard against any breakdowns and allow for maximum performance.

Routine Maintenance

Regular maintenance practices should include a thorough inspection. Ensure that all hoses are attached and undamaged and that the wiring harnesses are properly connected to each other and to an adequate power source. The following are important components of the foam marker and their respective maintenance requirements.

1. Liquid Strainer (a) (Figure 6): The liquid strainer is located in the foam solution tank on the end of the suction hose. It should be rinsed after each use or on a daily basis.
2. Orifice Disk (b) (Figure 6): The orifice disk is located behind the strainer on the end of the suction hose. Inspect the orifice disk occasionally to ensure that there are no debris or dirt plugging the disk's circular hole. **WARNING:** Do not operate the foam marker without this orifice disk. Such incomplete operation will result in damage to the compressor and will void the warranty.
3. Compressor Motor Bearings: The motor bearings are permanently lubricated ball bearings and do not require additional oil.
4. Solenoid Valve: No maintenance required.
5. Mixing Chamber Pads & Sponge (c and d) (Figure 7): Disassemble the mixing chambers and rinse out foam pads every season.

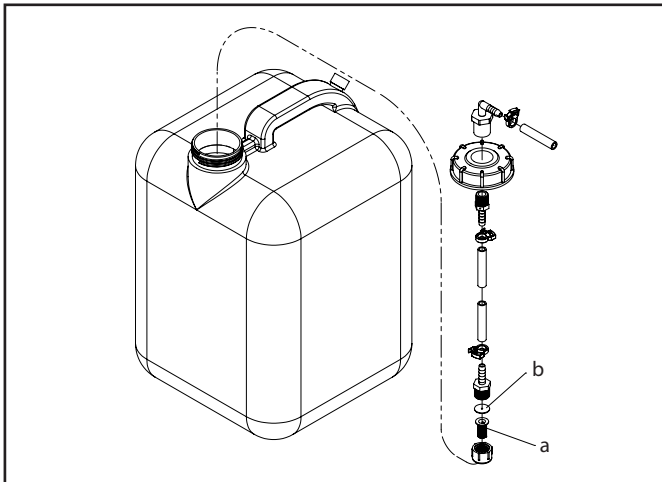

Figure 6: Foamer Tank Assembly

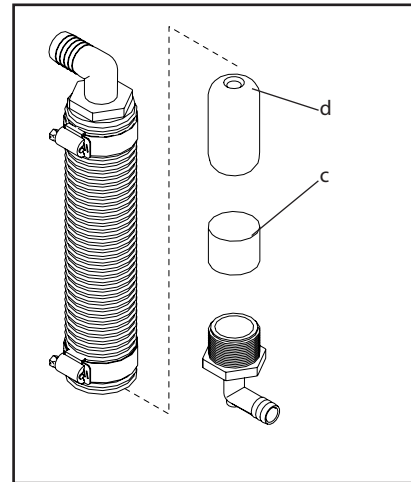

Figure 7: Mixing Chamber Pads

Winterizing your Foam Marker

It is essential that you winterize your foam marker to avoid damage and to allow for optimal performance. The winterization process should be undertaken before freezing conditions and/or after each season of use. Failure to winterize your foam marker will void the manufacturer's warranty.

1. Verify that the solution tank is empty and rinsed out. Add ½ gallon of RV Nontoxic antifreeze to the empty solution tank. It is not recommended to use engine antifreeze. Engine antifreeze can be harmful to humans, animals, crops, and the environment.
2. Engage the foam marker until both the left and right side of the system are flushed.
3. Store the foam marker or the equipment that the foam marker is mounted on in a dry location away from the elements.

Maintenance Instructions

Troubleshooting

During your many years of using the foam marker, it is possible that you will encounter minor problems that can be easily fixed. The following problems and respective causes and solutions should cover most of the potential problems that you may face. If you do encounter problems, please attempt to use this troubleshooting section to solve the problem. If you are unable to fix the problem please contact the original retailer for service.

Problems/Symptoms	Possible Causes	Solutions
Motor Will Not Run	Loose wire connections	Inspect wires and connections
	Blown fuse	Replace fuse on wiring harness
	Malfunctioning switch	Replace switch
	Inadquate power source	Connect power wires directly to 12 volt 15 amp. power supply
No Foam Output	Broken or bent leaf valve inside the compressor	Replace leaf valve (See compressor breakdown on page 12)
	Discharge hose is pinched or kinked	Locate problem area and fix or replace the hose
	Plugged orifice disk or strainer on the end of the suction hose	Clean or replace the orifice disk or stainer (See figure 6, page 7)
	Low voltage (11 volts or less) to compressor	Connect to 12 volt, 15 amp power supply
Foam Only On One Side	Low voltage to solenoid valve	Switch to an adequate power source
	Faulty wiring or switch	Replace wiring and/or switch
	Solenoid valve burned out	Replace the solenoid valve (ref # 24)
Low Foam Rate	Partially plugged orifice disk or strainer on the end of suction hose	Clean or replace the orifice disk or stainer (See figure 6, page 7)
	Incorrect mixture of foam concentrate	Use an approved foam concentrate and follow manufacturer's mixing instructions
	Water being used is hard	Use softened or rain water
	Low voltage (11 volts or less) to compressor	Connect to 12 volt, 15 amp power supply
	Broken or bent leaf valve inside the compressor	Replace leaf valve (See compressor breakdown on page 12)
Discharge Tube Leaks	Bolt on the top of discharge tube is no longer sealed	Wrap Teflon tape around the bolt threads and replace the bolt

Maintenance Instructions

Wiring Schematic

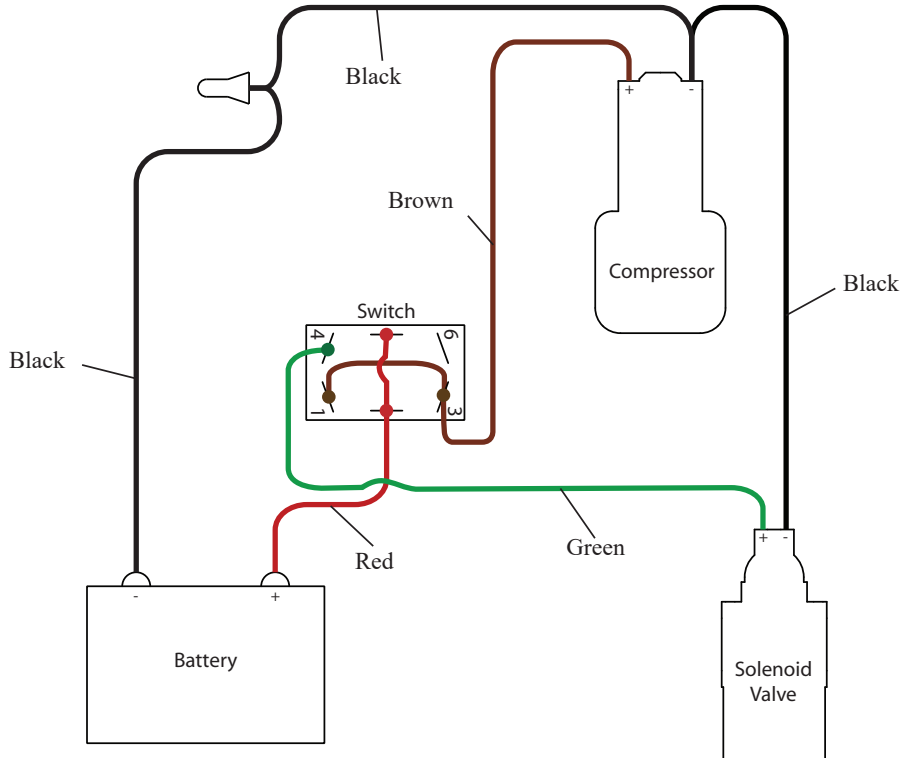

Breakdowns & Parts Lists

Foam Marker Breakdown

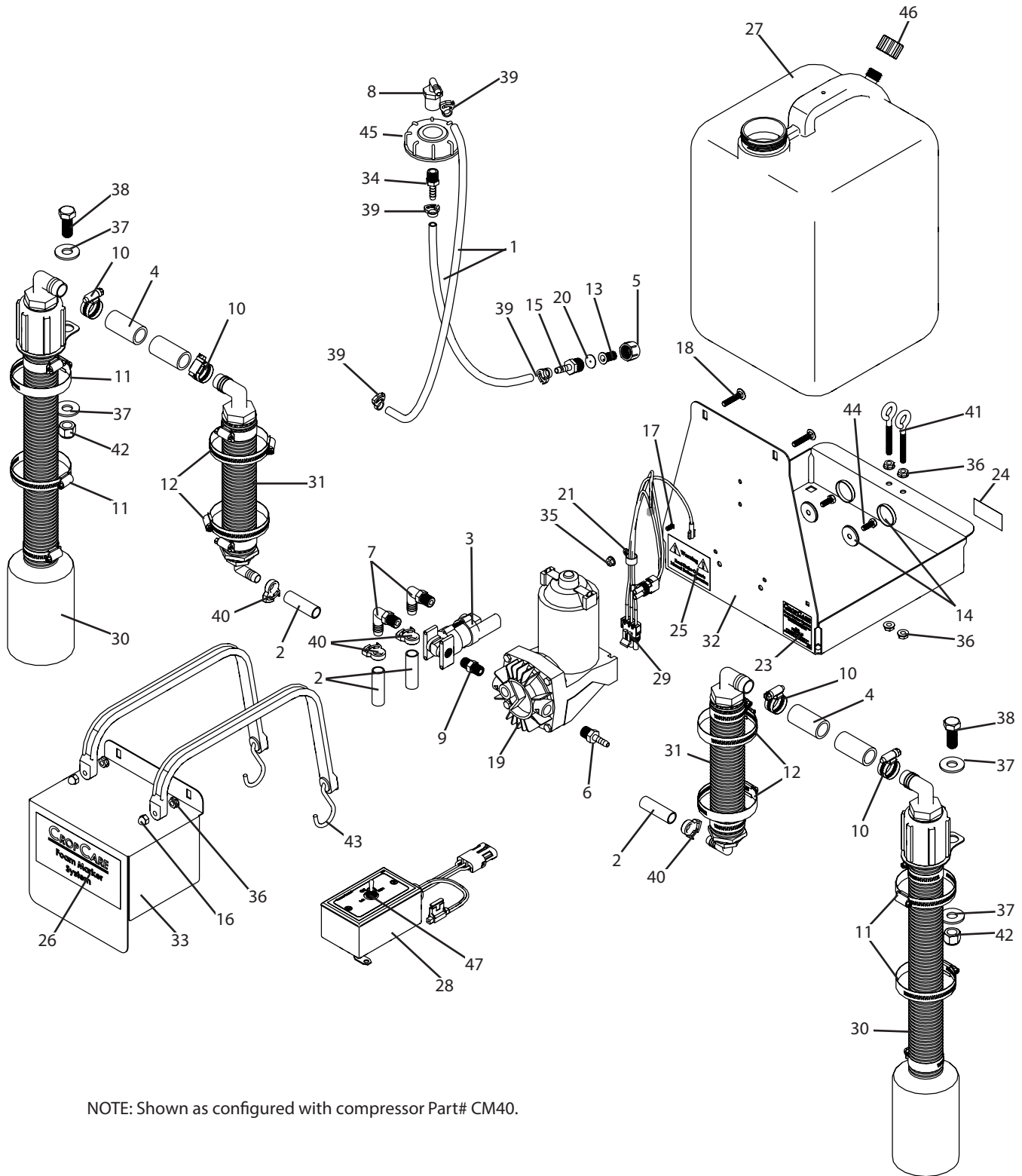

NOTE: Shown as configured with compressor Part# CM40.

Breakdowns & Parts Lists

Foam Marker Breakdown

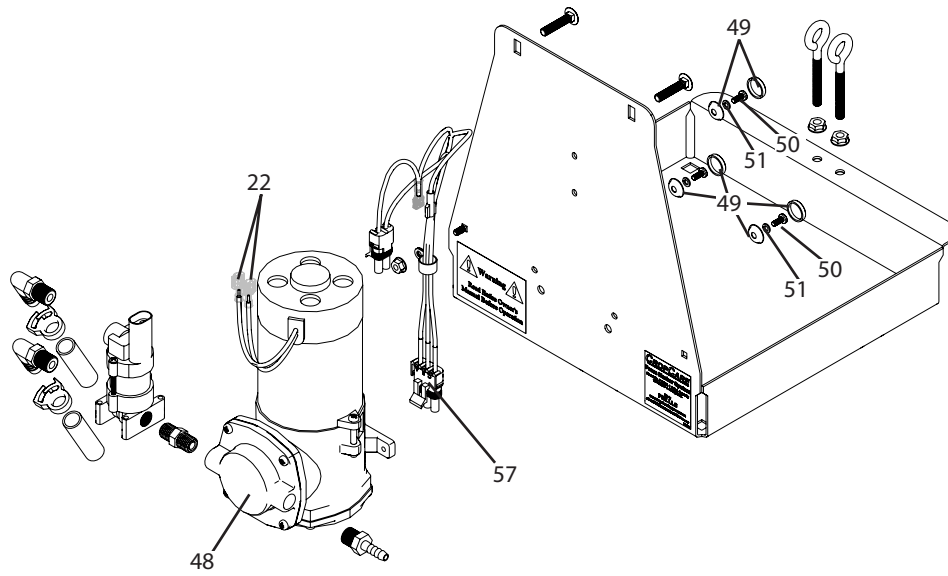

NOTE: Shown as configured with compressor Part# GZ35-12.

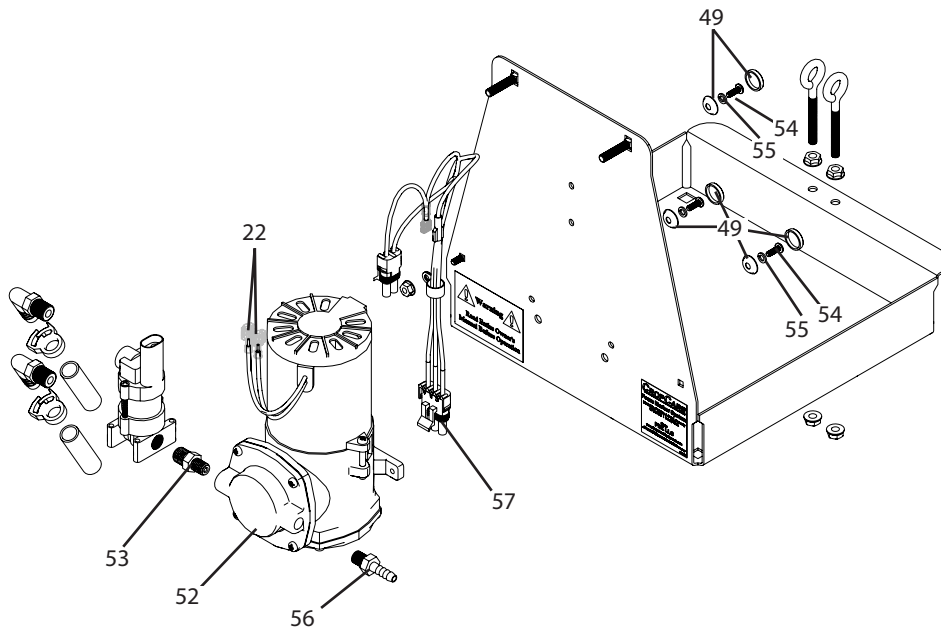

NOTE: Shown as configured with compressor Part# 107CDC20.

Breakdowns & Parts Lists

Foam Marker Parts List

Ref #	Qty.	Part Number	Description
1	34"	1954	Tubing, Vinyl 1/4" ID x 3/8" OD 55 PSI
2	1	1971-33L	Tubing, Vinyl 33 FT Roll 1/2" ID x 5/8" OD 30 PSI
3	1	2204AWP	Solenoid, 3-Way 1/4" FPT 0.5 GPM 40 PSI 12V
4	1	3003-50L	Hose, Suction 3/4" 50 FT Roll Clear PVC 100 PSI
5	1	38027	Cap, Nozzle Tip/barb 11/16-16 UNF Poly
6	1	3A1414	Adapter, Hose 1/4" MPT x 1/4" HB
7	2	3EL1412	Elbow, Hose 90° 1/4" MPT x 1/2" HB
8	1	3EL14F	Elbow, Hose 90° 1/4" FPT x 1/4" HB
9	1	6468	Nipple, Brass w/ Hex 1/4" MPT
10	4	6810052	Hose Clamp, 1/2" - 1-1/16" SS
11	4	6828	Hose Clamp, 1-1/4" - 2 1/4" SS
12	4	6864052	Hose Clamp, 2-1/2" - 4-1/2" SS
13	1	8079PP100	Strainer, Tip 100 Mesh Green Poly Body SS Screen
14	2	91620A970	Cap, Snap Screw Head 1/4" Screw
15	1	A3814BR	Adapter, Hose 3/8" MPT x 1/4" HB Brass
16	2	AN14	Nut, Acorn 1/4-20
17	1	CB1024*12	Bolt, Carriage 10-24 x 1/2" Gr 2
18	2	CB14*114	Bolt, Carriage 1/4-20 x 1-1/4" Gr 2
19	1	CM40	Air Compressor, 1.27 CFM 40 PSI 12V 8A
20	1	CP491645	Orifice Plate, SS 0.088-0.306
21	1	DC2406	Clamp, Loom 3/8" Nylon
22	2	DC834005	Terminal, 16-14 Gauge Male (Fully Insulated)
23	1	DE221	Decal, F1500A Specs
24	1	DE222	Decal, 5 Gal. Foam Marker Model and Revision
25	1	DE39	Decal, "Warning Read Owner's Manual
26	1	DE51	Decal, Foamer Cover
27	1	F1503A	Tank, 5 gal White Foamer
28	1	F1507	Harness, Foamer Power End
29	1	F1509A	Wiring harness compressor end (CM40 compressor)
30	2	F1525	Drop Tube, Foamer, 3/4" Hose Barb
31	2	F1529	Foam Marker, Mixing Chamber
32	1	F1532	F1500A, Main Frame
33	1	F1533	F1500A, Compressor Cover
34	1	F2506	Adapter w/ breather hole, A1414BR
35	1	FN1024	Nut, Flange 10-24
36	6	FN14	Nut, Flange 1/4-20
37	4	FW12S	Washer, Flat, 1/2" SS
38	2	H12*114S	Bolt, Hex 1/2-13 x 1 1/4 SS
39	4	HC041	Clamp, Snap Grip 0.36" - 0.41" Size BB
40	4	HC067	Clamp, Snap Grip 0.59" - 0.67" Size F
41	2	N221119	Bolt, Eye Closed 1/4-20 x 3" Zinc
42	2	NNC12S	Nut, Lock Nylon 1/2-13 SS
43	2	TS15	Tarp Strap, 15" Rubber
44	2	H6X16M	Metric bolt, 6 x 16mm 1.0 pitch
45	1	F1505	Foamer Tank Lid

* Component part breakdowns are available.

** Lid part number without hole drilled.

*** Part is included in item 28.

+ Use part# F1534 with GZ35-12 and 107CDC20 compressors.

++ Includes lid (Item 45).

Breakdowns & Parts Lists

Foam Marker Parts List

Ref #	Qty.	Part Number	Description
46	1	6010-000-070 **	Breather cap (Lid) has a drilled out hole in center of lid
47	1	DC7300131 ***	Toggle switch, on-off-on
48	1	GZ35-12 *	Compressor, Diaphragm, 12V, 1/4 FPT ports
49	3	SC10S	Cap, Snap Screw Head #10 Screw
50	3	MR4X10M	Machine Screw, Phillips, Pan Head, 4M x 10M 7P Zinc
51	3	LW4M	Lock Washer, 4mm
52	1	107CDC20	Compressor, Diaphragm, 12V, 1/8 FPT ports
53	1	6468	Nipple, Brass w/ Hex 1/4" MPT
54	3	MR832*12	Screw, Machine 8-32 x 1/2" Zinc
55	3	LW10	Washer, Lock #10
56	1	3A1414	Adapter, Hose 1/4" MPT x 1/4" HB, Poly
57	1	F1534	Wiring harness compressor end (GZ35-12 compressor)

* Component part breakdowns are available.

** Lid part number without hole drilled.

*** Part is included in item 28.

Breakdowns & Parts Lists

CM40 Compressor Breakdown

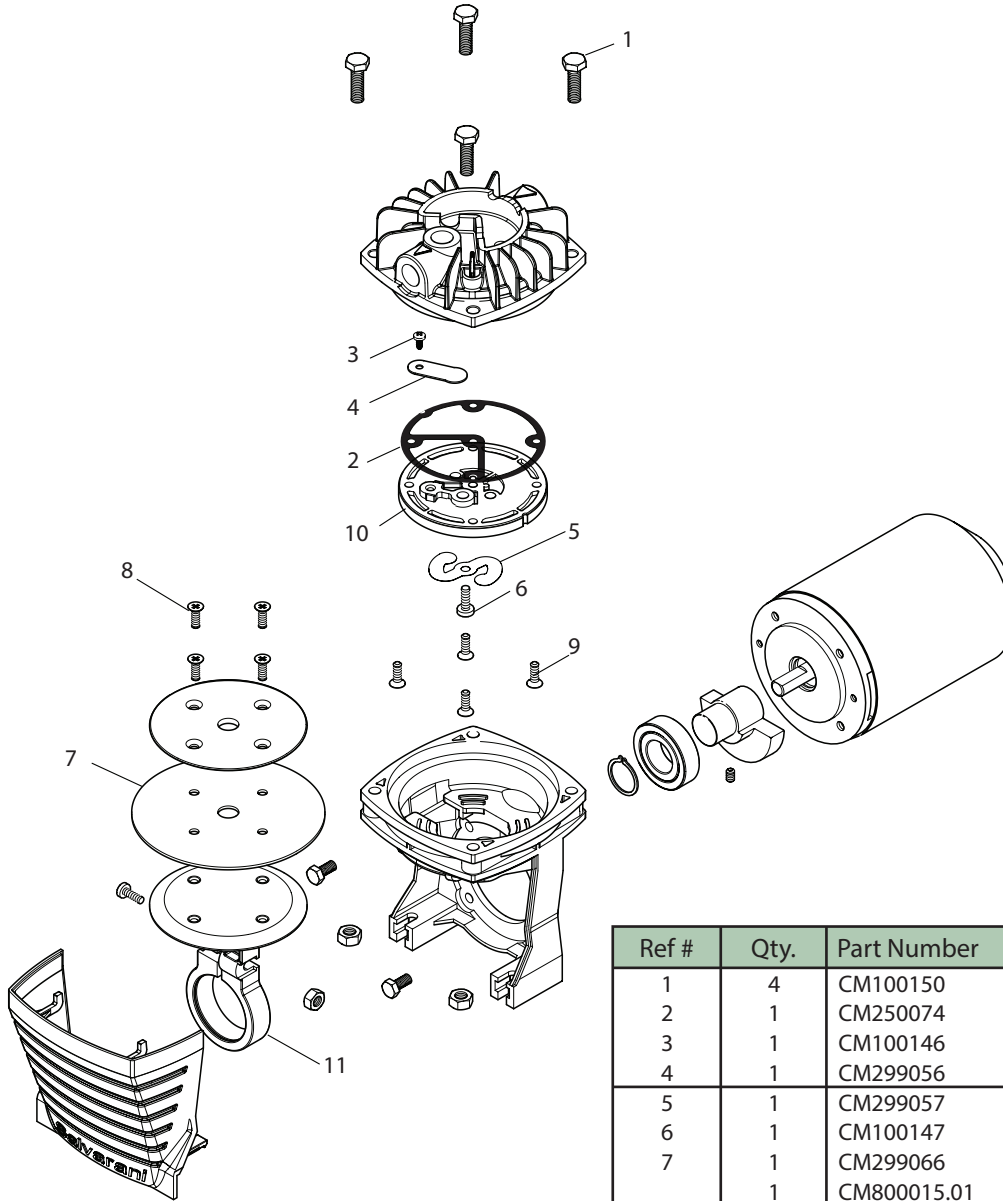

Ref #	Qty.	Part Number	Description
1	4	CM100150	Screw
2	1	CM250074	Head gasket
3	1	CM100146	* Screw
4	1	CM299056	* Leaf valve
5	1	CM299057	* Leaf valve
6	1	CM100147	* Screw
7	1	CM299066	* Rubber diaphragm
	1	CM800015.01	Diaphragm kit (Includes ref #'s 3-7)
8	4	CM100149	Screw
9	4	CM100148	Screw
10	1	CM299061	Valve plate
11	1	CM299067	Connecting rod

* Included in a complete kit

Breakdowns & Parts Lists

GZ35-12 Compressor Breakdown

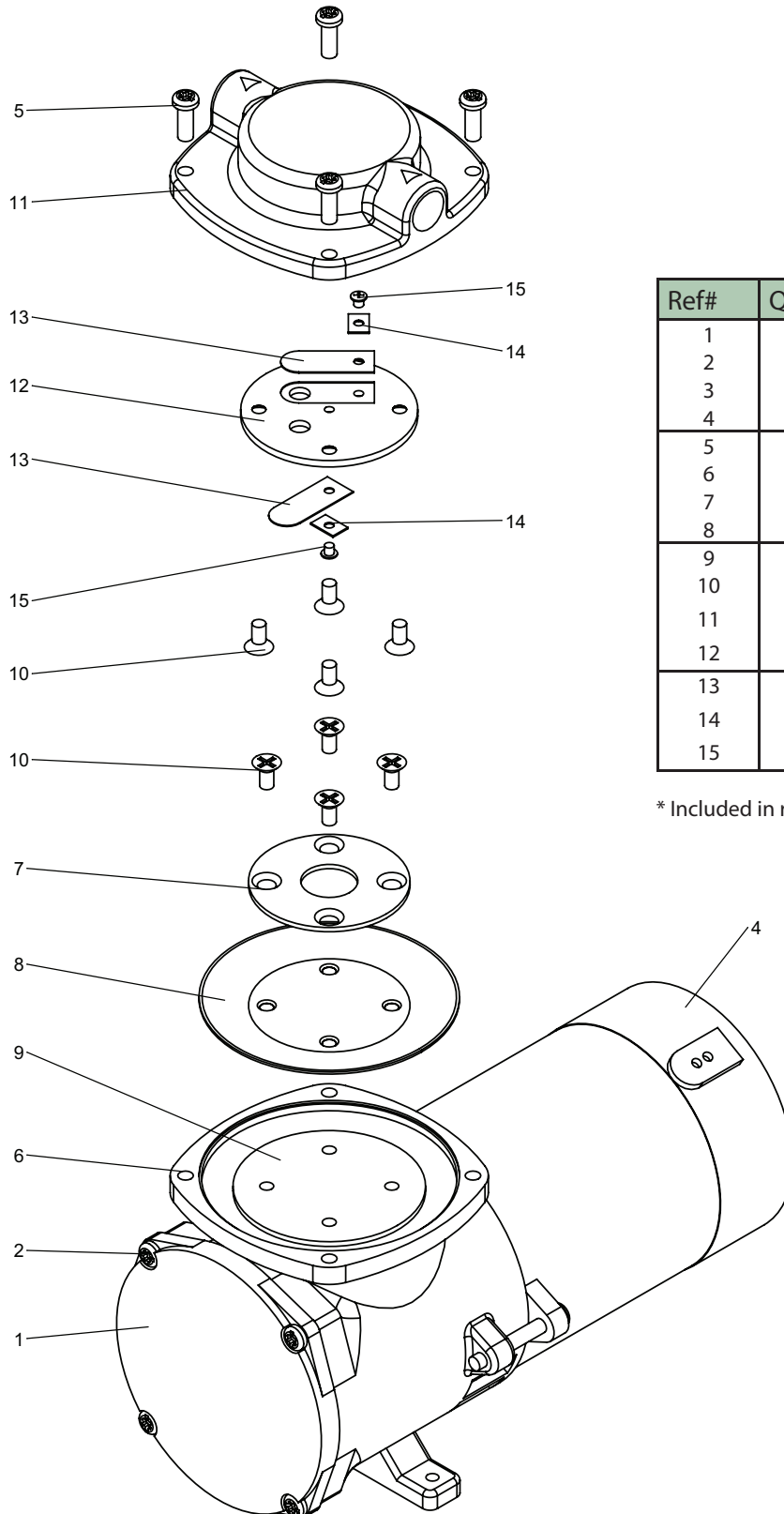

Ref#	Qty.	Part Number
1	1	Housing End Cap
2	4	Housing End Screws
3	2	Motor Housing Screws
4	1	Motor
5	4	Head Screws
6	1	Housing
7	1	Diaphragm Plate
8	1	Diaphragm *
9	1	Piston
10	8	Head Screws
11	1	Head
12	1	Valve Plate
13	2	Leaf Valve *
14	2	Leaf Valve Washer
15	2	Leaf Screws

* Included in repair kit (GZ35-15-RK)

F1525 Discharge Tube Breakdown

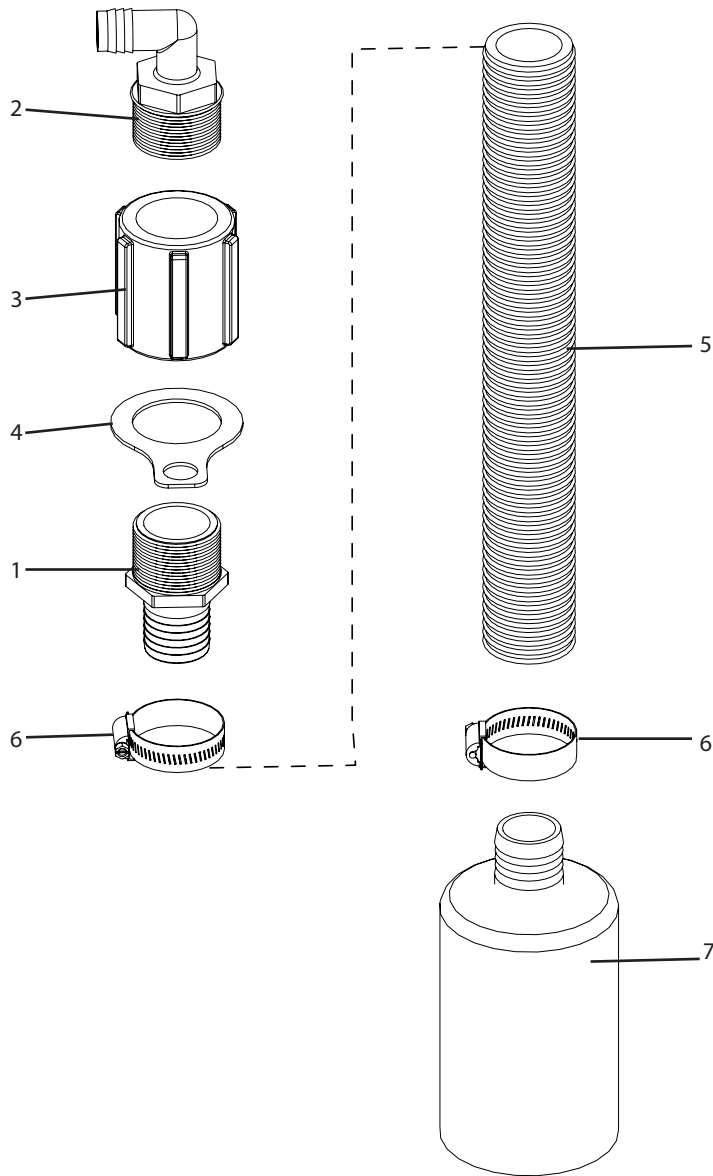

Ref#	Qty.	Part Number	Description
1	1	3A114	Fitting, Hose 1-1/4" MPT x 1-1/4" HB
2	1	3EL11434	Adapter, Hose 90° 1-1/4" MPT x 3/4" HB
3	1	8FC114	Coupler, 1-1/4" schedule 80 poly
4	1	F1531	Foam Marker Drop Tube Mount
5	13"	3511	Hose, EPDM Enforcer 1-1/4" 100 PSI (Black)
6	2	6824052	Hose Clamp, 1" - 2" SS
7	1	F1526	Foamer Drop Tube, Boot

Breakdowns & Parts Lists

F1529 Mixing Chamber Breakdown

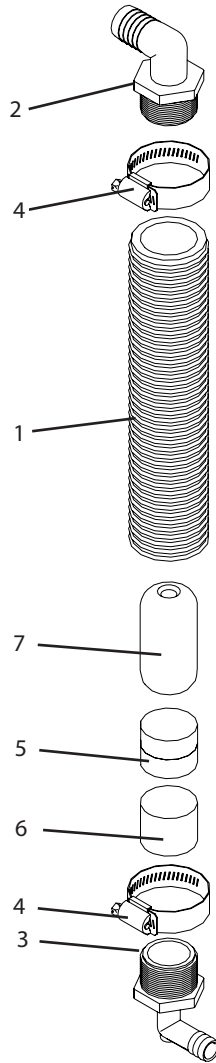

Ref#	Qty.	Part Number	Description
1	8"	3511	Hose, EPDM Enforcer 1-1/4" 100 PSI (Black)
2	1	3EL10034	Adapter, Hose 90° 1" MPT x 3/4" HB
3	1	3EL10012	Adapter, Hose Ell 1" MPT x 1/2" HB
4	2	6824052	Hose Clamp, 1" - 2" SS
5	2	F1529A	Mixing Chamber, Open Cell Pad (Black)
6	1	F1529B	Mixing Chamber, Closed Cell Pad (White)
7	1	F506	Sponge, Mixing Chamber

CropCare® Limited Warranty

Foam Markers: F1500A

Warranty Coverage

CropCare® hereby provides a Limited One (1) Year Warranty on Foam Markers, manufactured by CropCare®. Foam Markers manufactured by CropCare® are warrantied against any manufacturer's defects in any of the foam marker's components in the 12 months following the original date of purchase.

Defective components will be repaired or replaced at the discretion of the manufacturer. It is the responsibility of the purchaser to return warranted components to the manufacturer. This warranty is limited to the repair or replacement of foam marker components only. CropCare® is not to be held liable for incidental or consequential damages of any kind. This warranty covers the purchaser of this foam marker and any other owners who own it during the one year warranty period.

To retain the warranty, the foam marker must be operated and maintained as ascribed by its owner's manual. For warranty service, please have a copy of the purchase invoice available.

Warranty Is Void if:

1. The foam marker has been subjected to, in the opinion of CropCare®, negligent handling, misuse, an accident, or if instructions in the owner's manual were not followed.
2. The foam marker's components have been altered in any manner or repairs have taken place with unapproved parts. Alterations include adjusting the foam rate by any means.
3. The foam marker and its components were subject to freezing or were allowed to get wet repeatedly.
4. A non-approved foam concentrate was used such as dish soap, hand soap, or any other unapproved cleaning solution.
5. The foam marker was powered by a power source other than a 12 volt, 15 amp DC power source.

CROPCARE

Manufactured by PBZ LLC
A Paul B Zimmerman Inc. Company
www.CropCareEquipment.com